

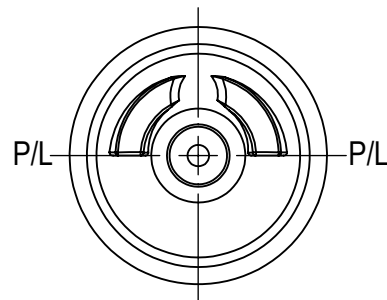

AVAILABLE:

1. SKU#100078, CLEAR

THIS DRAWING CONTAINS PROPRIETARY INFORMATION OF CONSUMERS PACKAGING GROUP INC. NEITHER THIS DRAWING OR ITS CONTENTS MAY BE REPRODUCED IN ANY FORM, FOR ANY PURPOSE, UNLESS WRITTEN CONSENT IS GIVEN BY CONSUMERS PACKAGING INC.



BOTTLE SPECIFICATIONS

MATERIAL: PETE	FILL CAPACITY: 60ML ± 3ML
WEIGHT: 9g ± 1g	OVERFLOW CAPACITY: 66ML ± 3.5ML
 <b>CONSUMERS PACKAGING GROUP INC.</b> TEL: 416-504-5200; FAX: 416-504-0707; sales@consumerspackaging.com	
DWN. BY: Y.F.	DATE: 26/06/09
APR. BY:	DATE:
SCALE: 1:1	DESCRIPTION: 60ML/2 OZ CYLINDER
	DRAWING NO: CPG-1082-A-V01-R01